



DNH

HEAD OFFICE, NORWAY

DNH AS

Phone..... + 47 35 98 56 00

E-mail..... dnh@dnh.no

Web-Site..... www.dnh.no

ENGLAND

DNH WW Ltd

Phone..... + 44 1908 275 000

Fax..... + 44 1908 275 100

E-mail..... dnh@dnh.co.uk

TUNNEL-500 / DUP-40(T)

GERMANY

DNH GmbH

Phone... + 49 040 6569 30-0

Fax..... + 49 040 6569 30-30

E-mail..... dnh@dnh.de

USA

DNH Speakers Inc

Phone..... + 1 484 494 5790

Fax..... + 1 484 494 5793

E-mail..dnh@dnhspeakers.com

ISO 9001 CERTIFIED

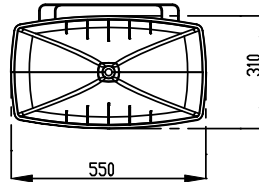
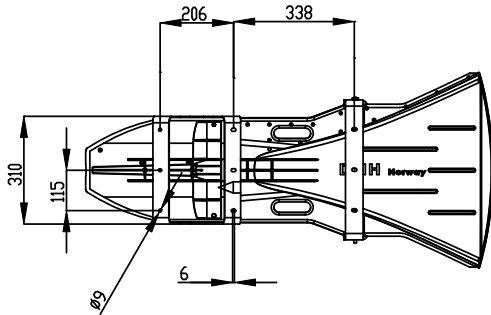

CIRCUIT DIAGRAM

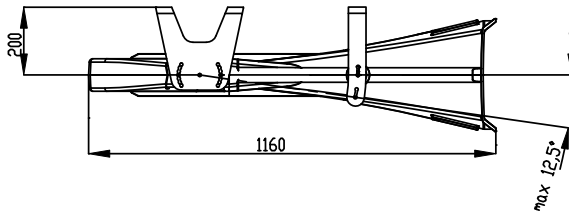
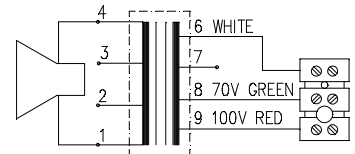

DUP-40

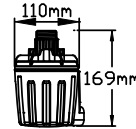

Secondary nominal tapings	
1 : 4	40 W
1 : 3	23 W
2 : 4	15 W
1 : 2	12 W
3 : 4	6,0 W
2 : 3	3,0 W

Sound pressure levels at 1W/1m TUNNEL500/DUP-40

SPL vs Freq

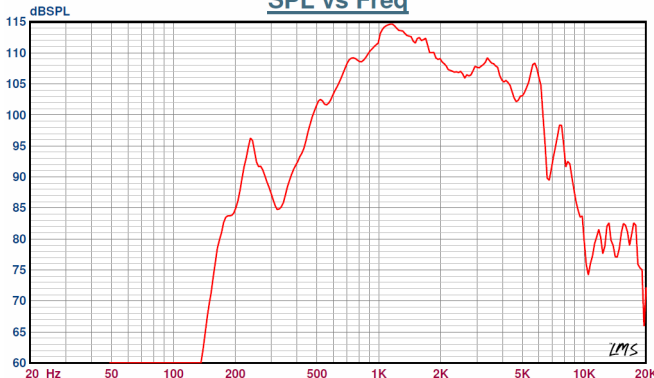

Specifications

Material / Color	ABS 5VB / Black
Mounting	2 brackets
Brackets material	V4A/A4/316
Termination	Ceramic terminal
Weight	13 Kg
IP-rating with DUP-40	67
Max. / min. amb. temp	90°C / -50°C
Rated power	40W
SPL 1W/1m	113 dB
SPL rated power	127 dB
Effective freq. range	250 – 8125 Hz
Dispersion (-6dB) 1kHz / 4kHz	40° / 35°
Options	Impedances, colors, labels

Installation, Operation and Maintenance Procedures

- TUNNEL-500 with DUP-40 is designed to be very directional and therefore excellent for tunnel applications.
- When connecting the driver use enclosed gasket without any lubricants. Screw the driver unit into TUNNEL-500 until the driver is in contact with the gasket, then continue screwing the driver for 90° to 115°. UNEF 1 3/8 - 18 thread.
- Remove lid, lead cable through cable gland, connect to terminal and choose required power on transformer.
- Screw lid back into place 2 Nm.
- Fasten brackets and choose wanted angle of loudspeaker with intervals of 2,5° max. 12,5°.
- To change the position of the loudspeaker please adjust the brackets (by loosening / tightening the screws) as required.
- For optimum performance, always use the correct voltage / power and operate within the frequency limits as stated.
- Do not open loudspeaker when energized.
- This loudspeaker is supplied with two years warranty against defective workmanship.

DNH reserves the right to alter specifications without notice.

