



# DNH

HEAD OFFICE, NORWAY  
**DNH AS**

Phone..... + 47 35 98 56 00  
E-mail..... dnh@dnh.no  
Web-Site..... www.dnh.no

ENGLAND  
**DNH WW Ltd**

Phone..... + 44 1908 275 000  
Fax..... + 44 1908 275 100  
E-mail..... dnh@dnh.co.uk

GERMANY  
**DNH GmbH**

Phone... + 49 040 6569 30-0  
Fax..... + 49 040 6569 30-30  
E-mail..... dnh@dnh.de

## BMD-60(T)

USA  
**DNH Speakers Inc**

Phone..... + 1 484 494 5790  
Fax..... + 1 484 494 5793  
E-mail..... dnh@dnhspeakers.com

ISO 9001 CERTIFIED

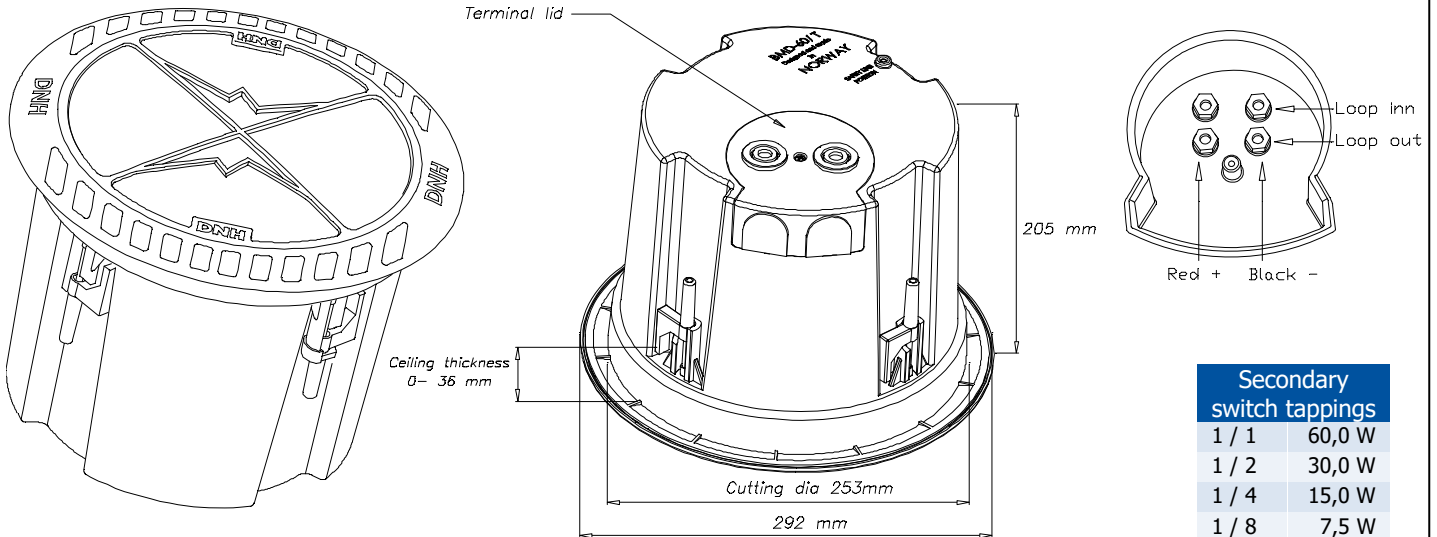

Secondary switch tapings	
1 / 1	60,0 W
1 / 2	30,0 W
1 / 4	15,0 W
1 / 8	7,5 W
1 / 16	3,5 W

### Sound pressure levels at 1W/1m

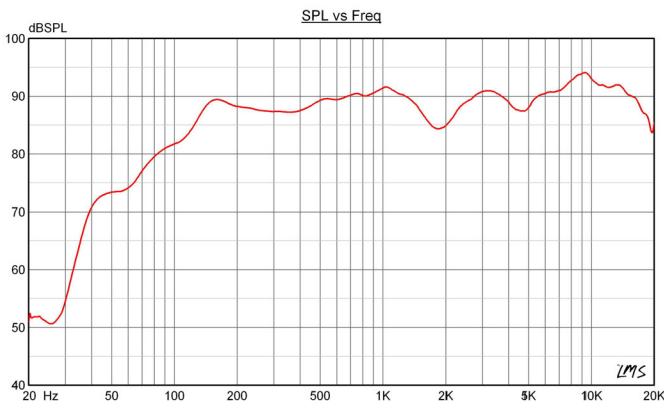

### Specifications

Material / Color	ABS / Black or White
Mounting	4 clamps
Termination	Screw terminal
Weight w/transformer	3,8 kg
IP-rating	44
Max. / min. amb. temp	90°C / -40°C
Rated power	60 W
SPL 1W/1m	90 dB
SPL rated power	109 dB
Effective freq. range	45 – 20000 Hz
Dispersion (-6dB) 1kHz / 4kHz	155° / 75° (baffle)
Options	Impedances, colors, labels

### Installation, Operation and Maintenance Procedures

- BMD-60(T) is delivered with one white grille, one black grille, terminal lid with two cable glands and four rubber plugs.
- BMD-60T is available with 60W transformer and tapping switch on front.
- Lead cable through cable gland and connect cable to terminal.
- Screw on lid with enclosed screw and tighten cable glands to assure a good sealing towards cable.
- Install box to the roof/wall by turning four screws clockwise and the four hooks will keep the loudspeaker in position.
- Screw grille (black or white) clockwise into fixed position.
- For optimum performance, always use the correct voltage / power and operate within the frequency limits as stated.
- Do not open loudspeaker when energized.
- This loudspeaker is supplied with two years warranty against defective workmanship.

DNH reserves the right to alter specifications without notice.

