



DNH

HEAD OFFICE, NORWAY
DNH AS

Phone..... + 47 35 98 56 00
Fax..... + 47 35 98 56 10
E-mail..... dnh@dnh.no
Web-Site..... www.dnh.no

ENGLAND
DNH WW Ltd
Phone..... + 44 1908 275 000
Fax..... + 44 1908 275 100
E-mail..... dnh@dnh.co.uk

GERMANY
DNH GmbH
Phone... + 49 040 6569 30-0
Fax..... + 49 040 6569 30-30
E-mail..... dnh@dnh.de

USA
DNH Speakers Inc
Phone..... + 1 484 494 5790
Fax..... + 1 484 494 5793
E-mail..... dnh@dnhspeakers.com

HPA-60

ISO 9001 CERTIFIED

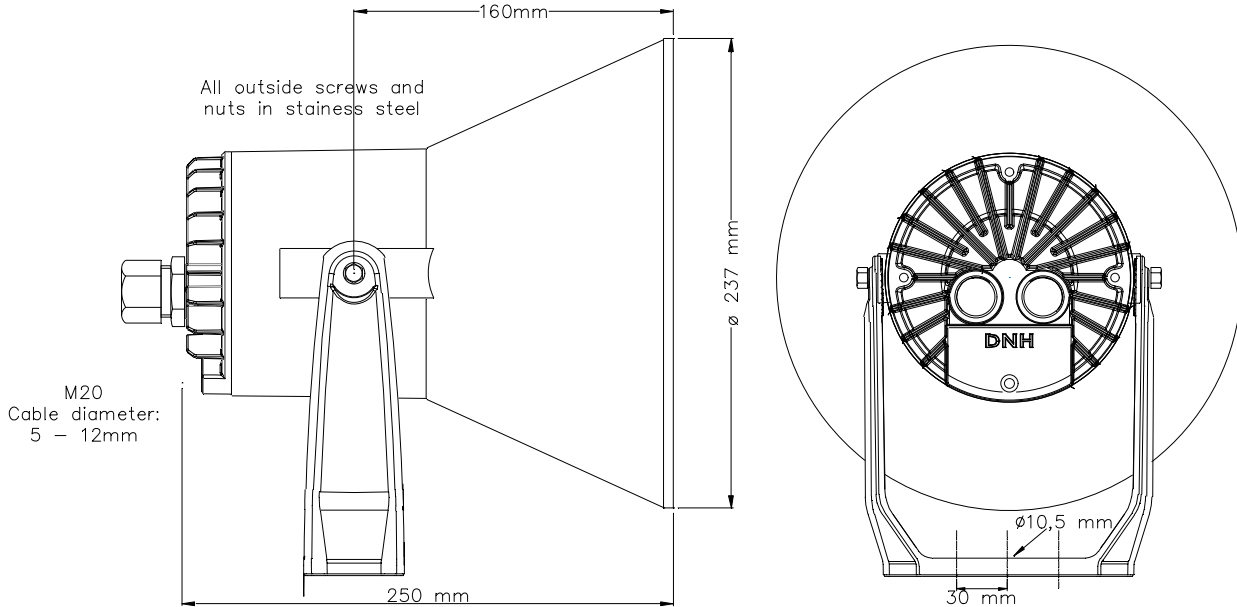

Sound pressure levels at 1W/1m
SPL vs Freq



Specifications

Material / Color	PA/aluminum alloy / RAL 7035
Mounting	Bracket
Termination	Internal screw terminal
Weight	1,9 kg
IP-rating	67
Max. / min. amb. temp	110 °C / -50 °C
Rated / max. power	60 W / 60 W
SPL 1W/1m	110 dB
SPL rated power	126 dB
Effective freq. range	310 – 8000 Hz
Dispersion (-6dB) 1kHz / 4kHz	110° / 32°
Options	Impedances, colors, labels

Installation, Operation and Maintenance Procedures

- Open lid by one screw, lead cable through cable gland and connect cable to terminal.
- Screw the lid by one screw and tighten cable gland.
- To change the position of the loudspeaker please adjust the bracket (by loosening / tightening the screws) as required.
- Stainless steel bracket is available as an option.
- For optimum performance, always use the correct voltage / power and operate within the frequency limits as stated.
- Do not open loudspeaker when energized.
- This loudspeaker is supplied with two years warranty against defective workmanship.

NB! Not available with transformer. Separate matching transformer can be delivered.

DNH reserves the right to alter specifications without notice

