



# DNH

HEAD OFFICE, NORWAY

**DNH AS**

Phone..... + 47 35 98 56 00

Fax..... + 47 35 98 56 10

E-mail..... dnh@dnh.no

Web-Site..... www.dnh.no

ENGLAND

**DNH WW Ltd**

Phone..... + 44 1908 275 000

Fax..... + 44 1908 275 100

E-mail..... dnh@dnh.co.uk

GERMANY

**DNH GmbH**

Phone... + 49 040 6569 30-0

Fax..... + 49 040 6569 30-30

E-mail..... dnh@dnh.de

USA

**DNH Speakers Inc**

Phone..... + 1 484 494 5790

Fax..... + 1 484 494 5793

E-mail..... dnh@dnhspeakers.com

ISO 9001 CERTIFIED

## Prosound-300(T)

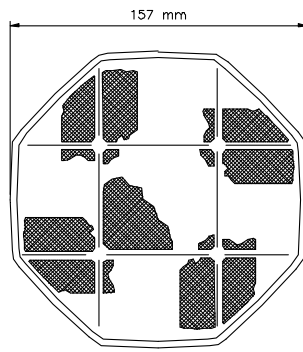
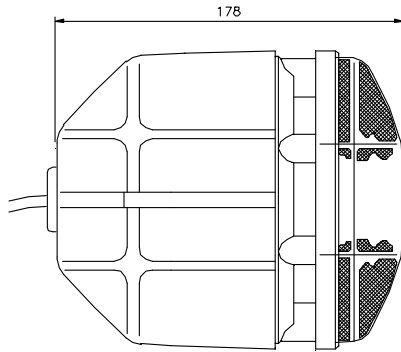

Prosound 300L



Prosound 300LB

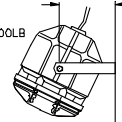

Prosound 300LS

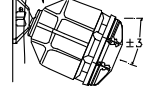

Circuit diagram

Transformer

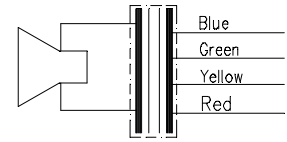

Low impedance

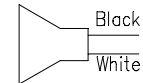

100 Volt transformer  
Primary connections

Red : Yellow	30,0 W
Yellow : Green	15,0 W
Green : Blue	7,5 W
Red : Green	5,0 W
Yellow : Blue	2,5 W
Red : Blue	1,5 W

Low impedance

Black : White	8 Ω
---------------	-----

Sound pressure levels at 1W/1m

SPL vs Freq

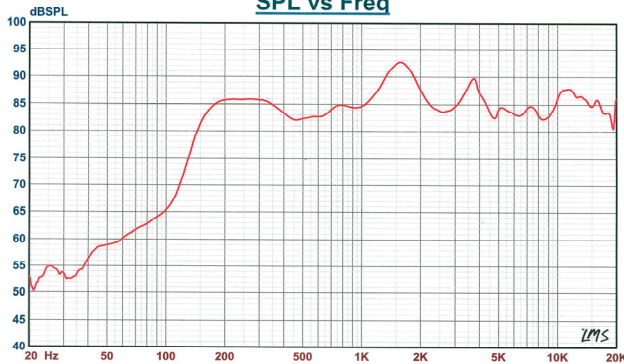

Specifications

Material / Color	Polyamid / Black or white (RAL 7035)
Mounting	Cable as pendant/Bracket/Swivel bracket
Termination	Cable, 2m
Weight (LT)	2,4 kg
IP-rating	54
Max. / min. amb. temp	90°C / -40°C
Rated power	30 W
SPL 1W/1m	85 dB
SPL rated power	100 dB
Effective freq. range	125 – 20000 Hz
Dispersion (-6dB) 1kHz / 4kHz	120° / 100°
Options	Impedances, colors, labels

### Installation, Operation and Maintenance Procedures

- Please specify the model when ordering (L, LB, LS).
- How to mount the loudspeaker:
  - Lamp-version (L): Ensure that the cable is fastened securely to the ceiling.
  - Bracket-version (LB): Screw the bracket to wall or ceiling with screws.
  - Swivel bracket version (LS): Read mounting instructions on carton box.
- To change the position of the loudspeaker:
  - Bracket version (LB): Adjust the bracket (by loosening / tightening the screws) as required.
  - Swivel bracket version (LS): Adjust the swivel base (by loosening / tightening the screws) as required.
- For optimum performance, always use the correct voltage / power and operate within the frequency limits as stated.
- This loudspeaker is supplied with two years warranty against defective workmanship.

DNH reserves the right to alter specifications without notice.

