



# DNH

HEAD OFFICE, NORWAY

**DNH AS**

Phone..... + 47 35 98 56 00

Fax..... + 47 35 98 56 10

E-mail..... dnh@dnh.no

Web-Site..... www.dnh.no

ENGLAND

**DNH WW Ltd**

Phone..... + 44 1908 275 000

Fax..... + 44 1908 275 100

E-mail..... dnh@dnh.co.uk

GERMANY

**DNH GmbH**

Phone... + 49 040 6569 30-0

Fax..... + 49 040 6569 30-30

E-mail..... dnh@dnh.de

USA

**DNH Speakers Inc**

Phone..... + 1 484 494 5790

Fax..... + 1 484 494 5793

E-mail..dnh@dnhspeakers.com

ISO 9001 CERTIFIED

## CR-6(T)

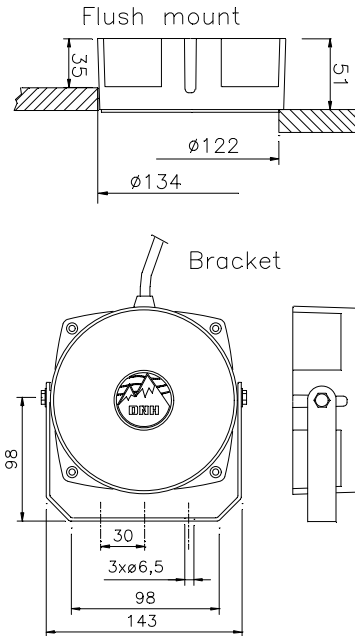
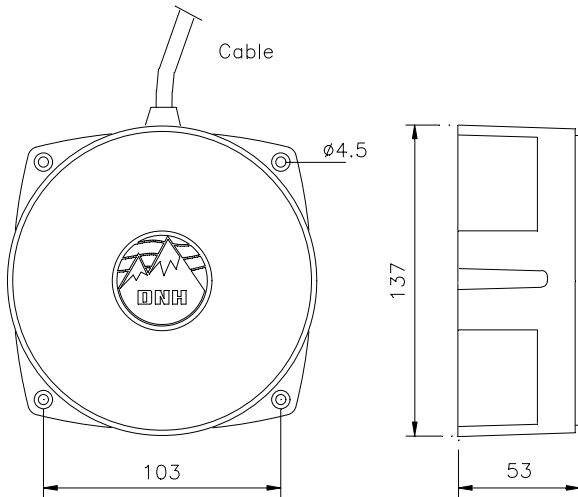

**100 V transformer  
Primary tapings**

|              |       |
|--------------|-------|
| Red : Yellow | 6 W   |
| Red : Green  | 3 W   |
| Red : Blue   | 1,5 W |

**8Ω version**

Red : Blue

Sound pressure levels at 1W/1m

**SPL vs Freq**

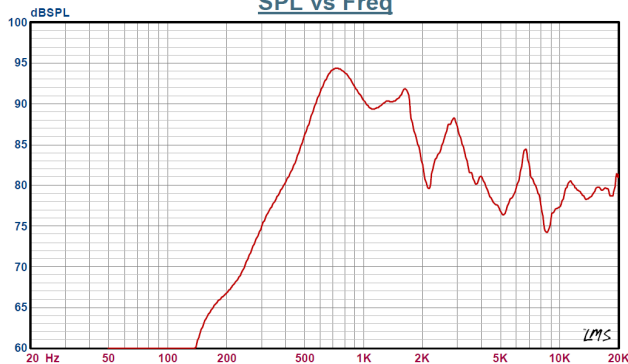

**Specifications**

|                               |                            |
|-------------------------------|----------------------------|
| Material / Color              | PA / RAL 9010              |
| Mounting                      | 4 screws or bracket        |
| Termination                   | Cable, 1 m                 |
| Weight w/transformer          | 2,2 kg                     |
| IP-rating                     | 67                         |
| Max. / min. amb. temp         | 90°C / -20°C               |
| Rated power                   | 6W                         |
| SPL 1W/1m                     | 85 dB                      |
| SPL rated power               | 93 dB                      |
| Effective freq. range         | 280 – 20000 Hz             |
| Dispersion (-6dB) 1kHz / 4kHz | 170° / 150°                |
| Options                       | Impedances, colors, labels |

### Installation, Operation and Maintenance Procedures

- Use four screws for mounting on wall, alternative flush mounting.
- When mounting with bracket, use the slit on each side to connect the bracket to the loudspeaker.
- CR-6 (T) is designed for clean room applications.
- Do not install this loudspeaker under water when operated with 100V line.
- For optimum performance, always use the correct voltage / power and operate within the frequency limits as stated.
- Do not open loudspeaker when energized.
- This loudspeaker is supplied with two years warranty against defective workmanship.

DNH reserves the right to alter specifications without notice.

